

WELCOME TO USING

LX2000 INFRARED MOTION SENSOR SWITCH !

LX2000 is a new generation infrared sensor developed by our long-term market forecast and investigation. It has strong stability, it gathers multi-function, practical, good appearance, wide working voltage, convenient installation, detection indication, multi-working mode, etc. It adopts SMT technique. It is accorded with European standard, it is suitable for automatic control for home, hotel and enterprise.

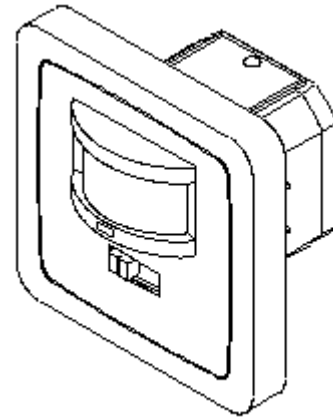

SPECIFICATION:

Power source: 90V/AC~240V/AC
Power frequency: 50~60 Hz

Detection distance: 12m max (<22°C)
(adjustable)

Detection range: >140°

Light-control: 3LUX~1000lux (adjustable)

Time-delay: 5sec~540sec(adjustable)

Rated load: 300W (110V/AC)

500W (220V/AC~240V/AC)

Installation height: 0.4m~1.8m
Power consumption: 0.45W (static 0.1W)

Detection motion speed: 0.6~1.5m/s

Sound control sensitivity: 30db ~90db(adjustable)

Working humidity: <93%RH

Working temperature: -20~40°C

FUNCTION:

- Multi-function: It has ON, OFF, light-control, high sensitive sound control, long distance, wide range infrared detection functions;
- Practicality: by the light-control it can control the sound-control and the ambient-light when the sensor works. It can work in various ambient-light day and night, it also can work only in low ambient-light; Time-delay can be adjusted by yourselves in stipulated range; infrared induction and sound control sensitivity can be controlled by yourselves;
- Good appearance: The surface design is facility, comely but not losing generosity, the style is elegance, it will not have accidented feeling after installation;
- Wide working voltage: 90V/AC~240V/AC 50~60Hz. You will not be worried when you go all over Europe carrying LX2000.
- Convenient installation: Two-installation modes for your selection. It can be installed in circular or quadrate junction box; you could fix the sensor with two screws on the junction box in circular one, also fix it with special installation shelf on sensor. In a word, whether the junction box installation orientation is true, LX2000 makes the installation flatly;
- Detection indication: The indicator lamp shines one time when it detects every time. You can validate the prominent quality of LX2000 at any time;
- Multi-working mode: You can select ON, OFF, infrared detection, infrared detection +sound control mode, if you select infrared detection + sound control mode, the lamp will be on automatically when you knock at the door or say "I am coming back" at night you come back home, it will make your home warmer and more romantic.



Correct moving orientation

incorrect moving orientation

INSTALLATION:

- Shut off the power
- Loosen the connection column on the bottom of sensor, plug the wire into connection hole, tighten the screws;
- Unload the surface of sensor, connect the sensor into connection box;
- If you want to install it in quadrate connection box, penetrate the setscrew into installation hole, block on radiator to aim at the installation hole on connection box, then tighten the screw; if you want to install it in circular one, you can use the same way as the quadrate, also adjust the sensor's position, tighten the setscrew on surface, then the fixing arm will open automatically, fasten the connection box
- Switch on the power then test it.

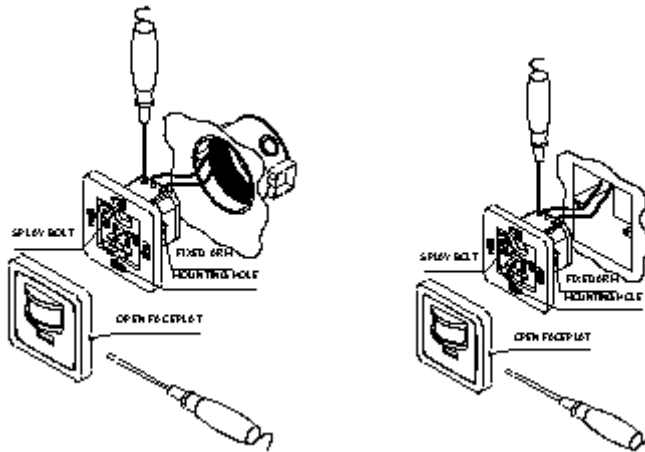

CONNECTION-WIRE DIAGRAM (see the right figure)

TEST:

- Set the function switch to "ON", set "SENS" to maximum, "MIC" to maximum; "LUX" to maximum; "TIME" to minimum;
- Switch on the power, the lamp should be on;
- Set the function switch to "OFF" after 30 sec, the lamp should be off, all functions should be in "stop" state;
- Set the function switch to "PIR" after 30sec, the inductor lamp will be on after 20sec when there is inductor signal whether the lamp is on or not. Under no inductor signal condition, the lamp should be off within 5~10sec, the lamp should be on again after 5sec. Set "LUX" to minimum, after it is off when there is no inductor signal condition, the lamp should be off in the daytime, but if you use a opaque object to cover sensor, the lamp should be on, then off within 5~10sec;
- Set the function switch to "+MIC", "LUX" to maximum, then the sensor is in the infrared detection +sound control mode, cover the detector, if the lamp is on, under no inductor signal condition, the lamp should be off after 5~10sec, after 5sec if you clap your hands, the lamp should be on, then off after 5~10sec (no inductor signal).

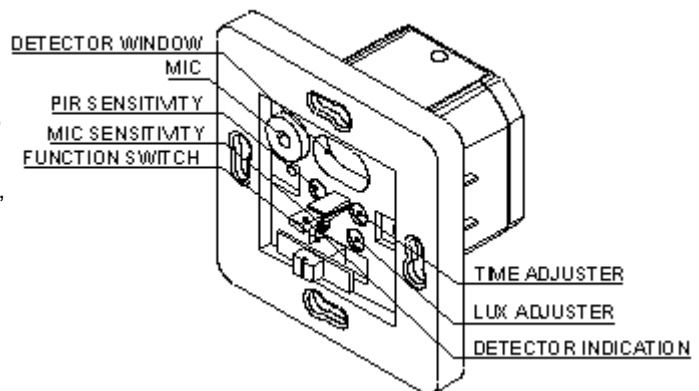
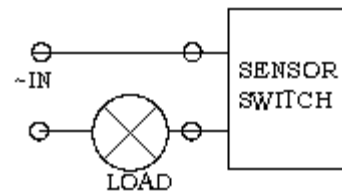

NOTE:

- Let electrician or experienced human install it;
- The unrest objects can't be regarded as the installation basis-face;
- There should be no hinder or unrest objects effecting detection in front of the detection window;
- Avoid installing it near temperature alteration zones, for example, air condition, central heating etc;
- Don't open the case for your safety if you find the hitch after installation;
- If there is any difference between instruction and products, please give priority to product, sorry not to inform you again

Warning:

Any two-lined product could not be used at fluorescent lamp lonely. If you really want to connect it into fluorescent lamp, the fluorescent lamp must be mixed with incandescent lamp (load must be parallel connection).

DO NOT PUT THE SENSOR INTO POWER DIRECTLY!!!