

an overvoltage category (CAT II) and pollution 2.

SAFETY SYMBOLS

	Important safety information, refer to the operating manual.
	Dangerous voltage may be present.
	Earth ground.
	Double insulation (Protection class II).

The AC/DC clamp meter complies with the requirements of the following European Community Directives: 89/336/EEC (Electromagnetic Compatibility) and 73/23/EEC (Low Voltage) as amended by 93/68/EEC (CE Marking).

However, electrical noise or intense electromagnetic fields in the vicinity of the equipment may disturb the measurement circuit. Measuring instruments will also respond to unwanted signals that may be present within the measurement circuit.

Users should exercise care and take appropriate precautions to avoid misleading.

SAFETY PRECAUTIONS

Follow all safety and operating instructions to ensure maximum personal safety during the operation and to ensure the meter is used safely and is kept in good operating condition.

Read these operating instructions thoroughly and completely before operating your meter. Pay particular attention to WARNINGS, which will inform you of potentially dangerous procedures. The instructions in these warnings must be followed.

Always inspect your meter and test leads for any sign of damage or abnormality before every use. If any abnormal conditions exist (i.e. broken test leads, cracked cases, display not reading, etc.), do not attempt to take any measurements.

Do not expose the instrument to direct sunlight, extreme temperature or moisture.

Never ground yourself when taking electrical measurements. Do not touch exposed metal pipes, outlets, fixtures, etc., which might be at ground potential. Keep your body isolated from ground by using dry clothing; rubber shoes, rubber mat, or any approved insulating material.

You always are careful when working with voltages above 60V dc or 30V ac rms. Keep fingers behind the probe barriers while measuring.

Never use the meter to measure voltages that might exceed the maximum allowable input value of any function.

Never touch exposed wiring, connections or any live circuit when attempting to take measurements.

MAINTENANCE

Before opening the case, always disconnect test leads from all energized circuits.

Never use the meter unless the back cover is in place and fastened completely.

Do not use abrasives or solvents on the meter. To clean it using a damp cloth and mild detergent only.

Qualified and trained service technicians should only perform calibration and repair of the meter.

GENERAL DESCRIPTION

The meter is an autoranging professional AC/DC clamp meter with digital and analog display, 3200 counts and 33-segment bar graph. For measuring DC and AC voltage, DC and AC current, Resistance,

Do not attempt calibration or service unless trained and another person capable of rendering first aid and resuscitation is present.

Frequency, Diode and Continuity Test with battery operated.

FRONT PANEL DESCRIPTION

Transformer jaws

Pick up the AC current or DC current flowing through the conductor.

Hold button

When this button is pushed, the display will keep the last reading and “” symbol will appear on the LCD until pushing it again.

Rotary switch

This switch is used to select functions and desired ranges as well as to turn on/off the meter.

R-H button

In autorange, press this button to select manual range and the “R-H” symbol will appear on the LCD.

In manual range, press this button momentarily to step up 1 range at one time, press this button for

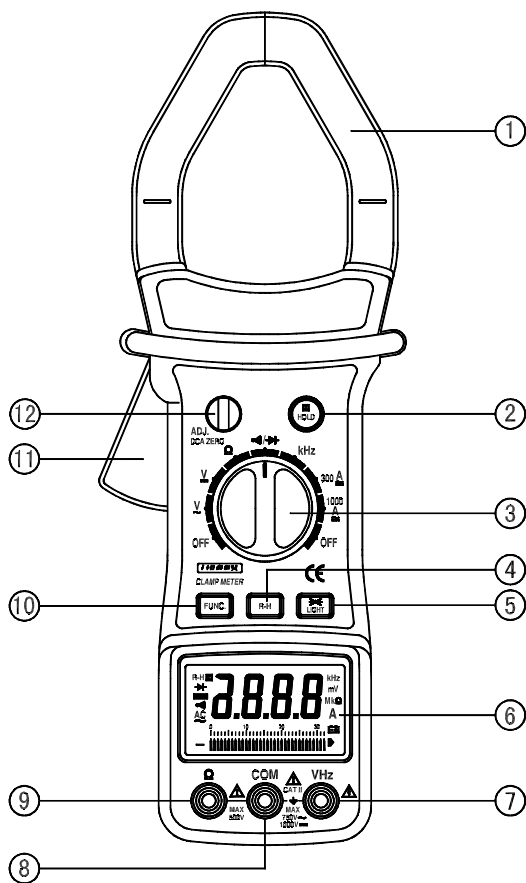

OPERATING INSTRUCTIONS

DC VOLTAGE MEASUREMENT

1. Connect the red test lead to the "VHz" jack and the black lead to the "COM" jack.
Set rotary switch at desired V $\overline{\text{---}}$ position.
2. Connect test leads across the source or load being measured.
3. Read voltage value on the LCD display along with the polarity of the red lead connection.

AC VOLTAGE MEASUREMENT

1. Connect the red test lead to "VHz" jack and the black test lead to the "COM" jack.
Set the rotary switch at desired V~ position.
2. Connect test leads across the source or load being measured.
3. Read voltage value on the LCD display.

AC CURRENT MEASUREMENT

1. Set the rotary switch at desired 300A or 1000A position. Push Func. button to 300A~ or 1000A~ range.
2. Press the trigger to open transformer jaw and to clamp one conductor only, making sure that the jaw is firmly closed around the conductor.
3. Read current value on LCD display.

DC CURRENT MEASUREMENT

1. Set the rotary switch at desired 300A or 1000A position.
2. Adjusting the DCA ZERO knob until the display show "0", when the meter does not measurement before.
3. Press the trigger to open transformer jaw and to clamp one conductor only, making sure that the jaw is firmly closed around the conductor.
4. Read current value on LCD display.

NOTE:

As the jaw core may remain some magnetic force after using for awhile. If the display can not reach "0", taking following process to correct it please:

1. Open the jaws several times.
2. Adjusting the DCA ZERO knob, making the display is "0".
3. Then work again.

RESISTANCE MEASUREMENT

Connect the red test lead to "(" jack and black test lead to the "COM" jack (The polarity of red lead is positive "+").

Set the rotary switch at desired ")" range position.

Connect test leads across the resistor to be measured and read LCD display.

If the resistance being measured is connected to a circuit, turn off power and discharge all capacitors before applying test leads.

NOTE:

1. If the resistance being measured exceeds the maximum value of the range selected or the input is not connected, an overrange indication "OL" will be displayed.
2. When checking in-circuit resistance, be sure the circuit under test has all power removed and that all capacitors have been discharged fully.
3. For measuring resistance above 1M(, the meter may take a few seconds to get stable reading. This is normal for high resistance measurements.
4. When the input is not connected, i.e. at open circuit, the figure "OL" will be displayed for the overrange condition.

MEASURING FREQUENCY

1. Connect the red test lead to "VHz" jack and the black test lead to the "COM" jack.
Set the rotary switch at desired kHz position.
2. Connect test leads across the source or load being measured.
3. Read frequency value on the LCD display.
- 4.

NOTE:

The input voltage should be between 200mV and 10V rms. ac. If the voltage is more than 10V rms. reading may be out of the accuracy range.

AUDIBLE CONTINUITY AND DIODE TEST

1. Connect red test lead to "(" jack, black test lead to "COM" jack. The polarity of red lead connection is positive "+".
2. Set range switch to "•||/ ➔" position and push the FUNC. button to select audible continuity or diode test mode.
3. If audible continuity is selected, connect test leads to two points of circuit to be tested. If continuity exists, built-in buzzer will sound.
4. If diode test mode is selected, connect the red and black leads to the anode and cathode of the diode under test. The forward voltage drop of this diode in V will be displayed.

SPECIFICATIONS

Accuracy is specified for a period of one year after calibration and at 18°C to 28°C (64(F to 82(F) with relative humidity to 80%.

GENERAL

Maximum voltage between terminals and earth ground	: CAT II 1000V dc or 750V ac rms. (sine)
Display	: LCD, 3200 counts and 33 segments bar graph updates 2-3/sec.
Ranging method	: Auto / Manual
Polarity indication	: "-" displayed for negative polarity
Overrange indication	: Only figure "OL" on the display
Jaw opening capability	: 55mm (Max conductor size)

Power	: 9V battery, NEDA 1604 or 6F22 006P
Low battery indication	: “  ” appears on the display
Operating environment	: 0 to 40°C
Storage temperature	: -10°C to 50°C
Temperature coefficient	: 0.1×specified accuracy) /°C (<18°C or >28°C)
Altitude	: 2000m
Size	: 282mm×104mm×47mm
Weight	: Approx. 550g.

DC VOLTAGE

Range	Resolution	Accuracy
3V	1mV	(0.8% of rdg (1 digit
30V	10mV	
300V	0.1V	
1000V	1V	(1.0% of rdg (2 digits

Input Impedance: 10M(

AC VOLTAGE

Range	Resolution	Accuracy
3V	1mV	(1.0% of rdg (5 digits
30V	10mV	
300V	0.1V	
750V	1V	(1.2 % of rdg (5 digits

Input Impedance: 10M(

Frequency range: 40Hz to 200Hz.

Response: Average responding, calibrated in rms. of a sine wave.

AC CURRENT

Range	Resolution	Accuracy
300A	0.1A	(600A (2.0% of rdg (10 digits
1000A	1A	(600A (3.0% of rdg (10 digits

Overload Protection: 1200A for 60 seconds maximum.

Frequency range: 50Hz to 60Hz.

DC CURRENT

Range	Resolution	Accuracy
300A	0.1A	(600A (2.0% of rdg (5 digits
1000A	1A	(600A (3.0% of rdg (5 digits

Overload Protection: 1200A for 60 seconds maximum.

RESISTANCE

Range	Resolution	Accuracy
-------	------------	----------

300(0.1((2.0% of rdg (10 digits
3k(1(
30k(10(
300k(0.1k(
3M(1k((2.5% of rdg (10 digits
30M(10k(

Maximum Open Circuit Voltage: 1.3V

Overload Protection: 250V dc or rms. ac for all ranges.

FREQUENCY

Range	Resolution	Accuracy
30kHz	10Hz	(2.0% of rdg (10 digits

Sensitivity: 200mV rms.

Input Limit: 250V ac.

AUDIBLE CONTINUITY AND DIODE

Range	Description
•	If continuity exists (about less than 18(, built-in buzzer will sound.
▶	Show the approx. Forward voltage of the diode.

REPLACING THE BATTERY

WARNING

Before attempting to open the case of battery, always be sure that test leads have been disconnected from measurement circuits. Close case and tighten screws completely before using the meter to avoid electrical shock hazard.

If “  ” appears on display, it indicates that the battery should be replaced. Use the following procedure to replacing the battery:

Disconnect test leads from any live source, turn the rotary switch to OFF, and remove the test leads from the input terminals.

The battery cover is secured to the bottom case by a screw. Using a screwdriver, remove the screw from the battery cover and remove the battery cover.

Remove battery and replace with a new equivalent 9 volt battery.

Replace the battery cover and reinstall the screw.

ACCESSORIES

- (Operator’s instruction manual
- (Set of test leads
- (Gift box
- (9 volt battery. NEDA 1604 6F22 006P type

 CAUTION:

Using this appliance in an environment with a strong radiated radio-frequency electromagnetic field (approximately 3V/m), may influence its measuring accuracy. The accuracy can be reduced to ((12% of reading + 6 digits).

The measuring result can be strongly deviating from the actual value.

The measuring result can be strongly deviating from the actual value.

The measuring result can be strongly deviating from the actual value.

The measuring result can be strongly deviating from the actual value.